



F Series - F4 201

Li-Ion Pallet Truck 2.0T

- Power and capacity upgrade for productivity boost
- Plug in&out Li-ion batteries maximize flexibility
- Parts compatibility lowering operation costs
- Platform-based design to maximize competitive advantage in the market
- Cost-saving operations throughout the distribution cycle

LI-ION
TECHNOLOGY

EP EQUIPMENT CO.,LTD
www.ep-equipment.com

F Series - F4 201

■ Power and capacity upgrade for productivity boost

The powerful 48V electric system means the F4 201 achieve a load capacity up to 2 tons, which brings a productivity boost allowing you to lift more and move more.



■ Plug in&out Li-ion batteries maximize flexibility

F4 201 comes with two 24V/20Ah Li-ion batteries which can be easily replaced via plug in&out. This truck can operate more frequently thanks to fast charging and zero maintenance. Plus, its flip cover design protects batteries from water ingress, ensuring battery safety.



■ Newly designed tiller head combining both aesthetics and practicality

F4 201 adopts EP's newly designed tiller head, and it demonstrates clean and smooth lines. The square tube is strong and ensures robustness and reliability for daily operation.



■ Parts compatibility lowering operation costs

As a part of the F series, the F4 201 inherits market-proven components that help dealers to achieve better parts stock management and reduce parts inventory.



Why F Series ?

■ Platform-based design to maximize competitive advantage in the market

F series features the platform F, which simplifies the configuration of the truck and allows buyers to choose from different chassis by application. The product design provides value and creates a flexible product strategy by introducing new equipment that meets various market requirements.

■ Cost-saving operations throughout the distribution cycle

4 units per box as standard wholesale supply reduces overall spending through the entire distribution process from shipping, storage and handling as well as delivery. F4 201 accommodates 164 units in a 40' shipping container compared to 108 units of EPT20-ET2L, that can reach as high as 50% of ocean freight charges reduction.

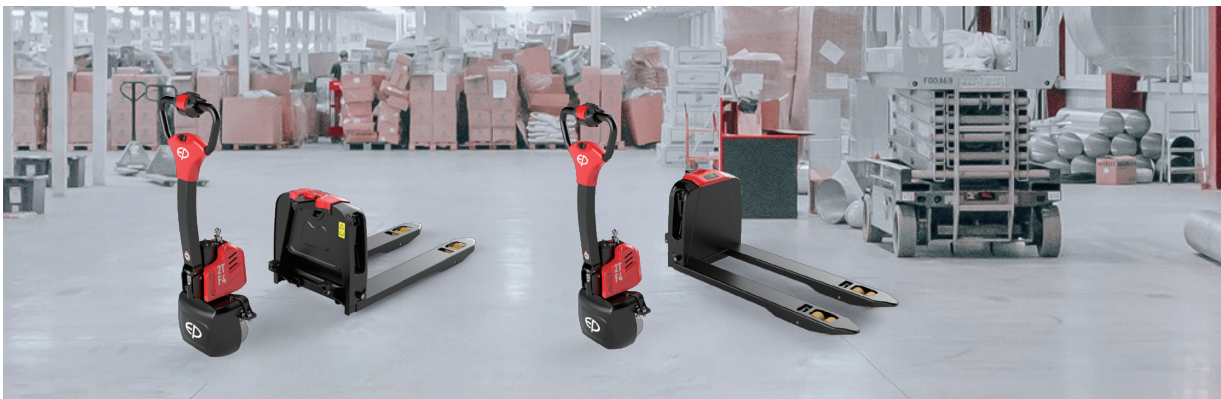

Li-Ion Pallet Truck 2.0T

F Series - F4 201

Distinguishing mark	1.1	Manufacturer			EP
	1.2	Model designation			F4 201
	1.3	Drive			Electric
	1.4	Operator type			Pedestrian
	1.5	Load capacity	Q	kg	2000
	1.6	Load center distance	c	mm	600
	1.8	Load distance, centre of drive axle to fork	x	mm	950
	1.9	Wheelbase	y	mm	1180
	Service weight	2.1	Service weight		kg
2.2		Axle loading, laden front/rear		kg	620/1520
2.3		Axle loading, unladen front/rear		kg	100/40
Tyres/chassis	3.1	Tyre type			Polyurethane
	3.2	Tyre size, front			210mm×70mm
	3.3	Tyre size, rear			80mm×60mm
	3.4	Additional wheels (castor wheels)		mm	74mm×30mm
	3.5	Wheels, number front/rear (x=drive wheels)		mm	1x, —/4
	3.6.1	Tread width, front	b ₁₀	mm	—
	3.7.1	Tread width, rear	b ₁₁	mm	410 (535)
Dimensions	4.4	Lift height	h ₃	mm	105
	4.9	Height of tiller handle in drive position min./max.	h ₁₄	mm	750/1190
	4.15	Lowered height	h ₁₃	mm	85
	4.19	Overall length	l ₁	mm	1550
	4.20	Length to face of forks	l ₂	mm	400
	4.21	Overall width	b ₁ /b ₂	mm	590 (695)
	4.22	Fork dimensions	s×e×l	mm	50X150X1150
	4.25	Distance between fork-arms	b ₅	mm	560 (685)
	4.32	Ground clearance, center of wheelbase	m ₂	mm	30
	4.34.1	Aisle width for pallets 1000×1200 crossways	Ast	mm	2160
	4.34.2	Aisle width for pallets 800×1200 lengthways	Ast	mm	2025
	4.35	Turning radius	Wa	mm	1360
Performance data	5.1	Travel speed, laden/unladen		km/h	4.5/5
	5.2	Lifting speed, laden/unladen		m/s	0.016/0.020
	5.3	Lowering speed, laden/unladen		m/s	0.058/0.046
	5.8	Max. gradeability, laden/unladen		%	8/16
	5.10	Service brake			Electromagnetic
Electric-engine	6.1	Drive motor rating S2 60 min		kW	0.9
	6.2	Lift motor rating at S3 15%		kW	0.7
	6.4	Battery voltage/nominal capacity		V/Ah	48/20
	6.5	Battery weight		kg	10
	6.6	Energy consumption according to DIN EN 16796		kWh/h	0.18 ¹⁾
	6.7	Turnover output according to VDI 2198		t/h	88
	6.8	Turnover efficiency according to VDI 2198		t/kWh	473.12
	Drive/lift mechanism	8.1	Type of drive control		
10.5		Steering design			Mechanical
10.7		Sound pressure level at the driver's ear		dB(A)	74
15.1		Charger output current		A	—

If there are improvements of technical parameters or configurations, no further notice will be given.
The diagram shown may contain non-standard configurations.

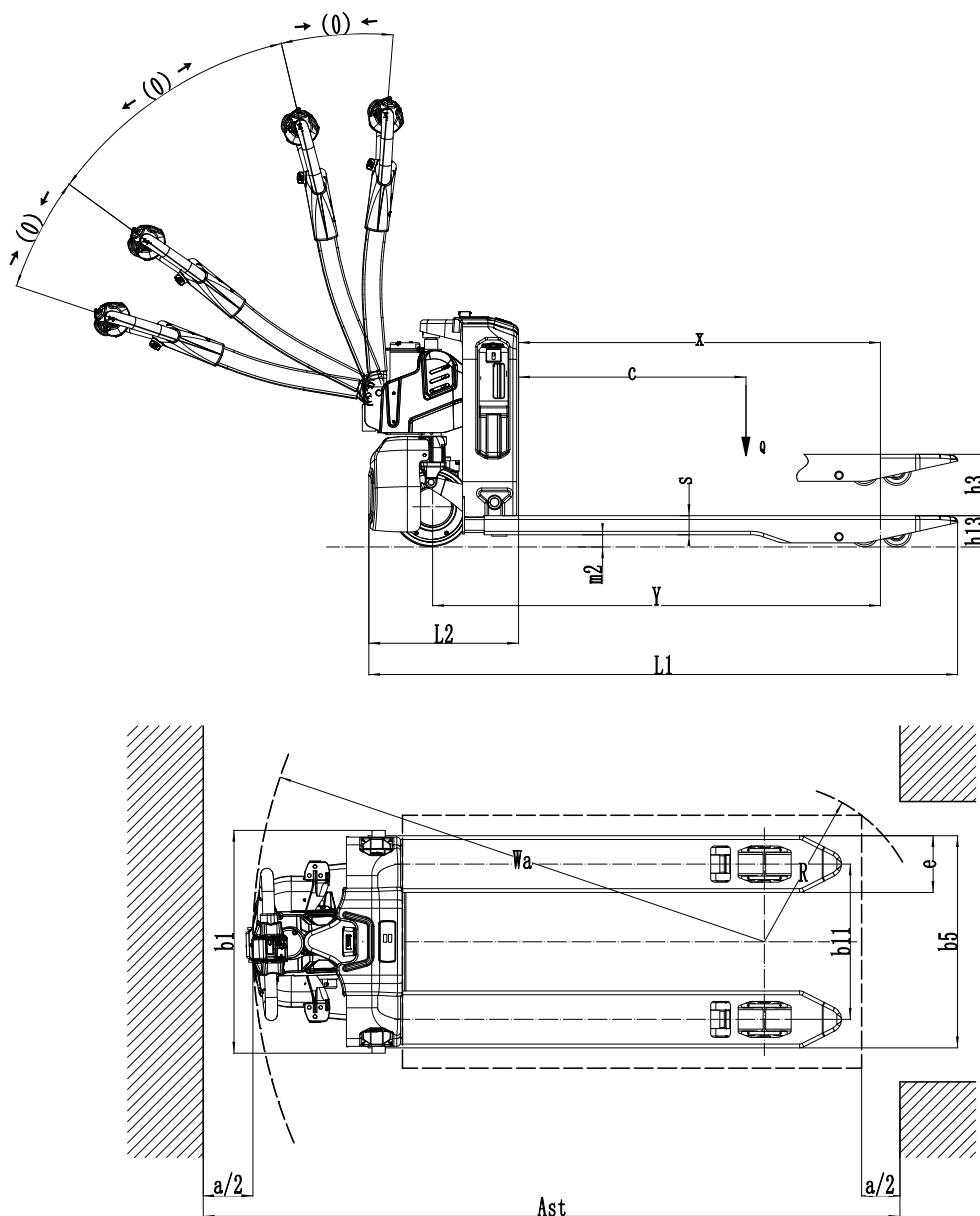

Option:

No.	Optional items	F4 201
1.1	Fork dimension	●1150*560○900*560○1000*560○1220*560○1350*560○1500*560○900*685 ○1000*685○1150*685○1220*685○1350*685○1500*685
1.3	Fork lowered height	●80
1.6	Drive cover off the ground	●55mm
2.1	Load wheel type	●Double○Single
2.2	Load wheel material	●PU
2.3	Drive wheel material	●PU
2.7	Battery capacity	●24V/20AH×2 ○24V/20AH×3 ○24V/20AH×4
2.8	Charger	●24V-5A external charger X2 ○24V-10A external charger X2
2.9	Battery indicator	●Without time
2.16	handle head type	●Square-tube tiller head
3.3	Castor wheels	●No○Yes and not customized
3.12	Buzzer	●Yes and not customized
3.16	Turtle speed	●Yes and not customized

Note: ●Standard ○ Optional - Inconformity